

Operations Manual

Endurance X1M Manual Dough Press w/ Mold - Model #: DP1100M



PROLUXE
WWW.PROLUXE.COM

Version: 122820

Congratulations on your selection of the Endurance X1M Manual Dough Press with Mold Insert. Proluxe is a leading manufacturer of food preparation and cooking equipment designed for the most demanding commercial kitchens. Proluxe equipment is a result of the highest quality engineering and time-tested design.

This manual includes installation, operation, and maintenance procedures for your new Endurance X1M Dough Press. Please read this manual carefully and keep it with your machine for key to proper operation and lasting service.

INSTALLATION

Domestic

Use a separate 15 amp AC circuit. Only industrial extension cords with proper wire size should be used; size 16/3 wire for distance up to 25 feet, and size 14/3 for distance up to 50 feet.

International

Use a designated 16 amp AC circuit. Only industrial extension cords with proper wire

size (2.5 sq. mm) shall be used. Make sure there is a proper electrical wall outlet located within reach of the cord and plug attached to the press.

Then place the dough press in an area which allows for “swing clearance” of the lower platen. The lower platen of the press requires room in which to rotate and suggest a minimum of 36 inches of unobstructed space in front of the press shown in FIG. 1.

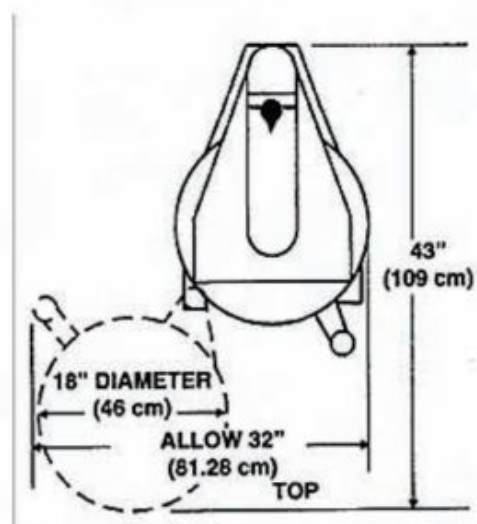

FIG. 1

Limited Machine Warranty

Proluxe warrants this dough press machine, when operated under normal conditions, to be free from manufacturing defects in material and workmanship for a period of one year on parts and labor from the invoice date.

This warranty will be effective only when Proluxe authorizes the original purchaser to return the product to the factory in Perris, California freight prepaid and only when the product, upon examination, has proven to be defective.

This warranty does not apply to any machine that has been subjected to misuse, negligence or accident. Proluxe shall not be liable for the injury, loss or damage, direct or consequential, arising out of the use or the inability to use the product. No claim of any kind shall be greater in amount than the sale price of the product or part to which claim is made.

This is the sole warranty given by the company, it is in lieu of any other warranties, expressed or implied, in law or in fact, including the warranties of merchantability and fitness for a particular use, and is accepted such by the purchaser in taking delivery of this product.

SPECIFICATIONS

Electrical:

120V/60Hz/1425W/11.9 Amps

Also available; specify when ordering:

- Voltage: 120/208/240
- Amps: 12.5/11.1/16.5
- Watts: 1500/2300/1500

Includes: 72" cord and NEMA approved plug.

Shipping Weight:

190lbs. (76kg.)

INTERNATIONAL SYMBOLS

Symboles internationaux



Power Off
éteindre



Power On
allumer



Hot Surface
surface chaude



Risk of Electrical Shock
Risque de choc électrique



Protective Earth Terminal
Borne de terre de protection



Caution - Warning
chaud - avertissement

SAFETY SUMMARY



Warning

To reduce the risk of electrical shock, do not remove or open cover. No user-serviceable parts inside. Refer servicing to qualified personnel.

Avertissement

Pour réduire le risque de choc électrique, ne pas retirer ou couvercle ouvert Aucune pièce réparable par l'utilisateur, reportez-vous à du personnel qualifié.



Warning

In case of power cord damage, do not attempt to repair or replace the power cord. Please contact the manufacturer or the local distributor.

Avertissement

Pour une protection continue contre l'incendie et de choc électrique, remplacer avec le même type et calibre du fusible. Mis fusible supplémentaire nominale max 3A, 120 Vac.



Warning

For continued protection against fire and electric shock, replace with the same type

and rating fuse. Listed Supplemental Fuse rated max 3A, 120Vac.

Avertissement

Pour une protection continue contre l'incendie et de choc électrique, remplacer avec le même type et calibre du fusible. Mis fusible supplémentaire nominale max 3A, 120 Vac.



Caution Hot

Avoid touching hot surfaces while operating the machine.

Attention à chaud

Évitez de toucher les surfaces chaudes lorsque vous utilisez la machine.



Caution

When servicing or cleaning the machine, make sure that the power cord is removed from the wall socket.

During normal operation, the base of the machine must be installed or placed above the wall socket.

Avertissement

Lors de l'entretien ou du nettoyage de la machine, assurez-vous que le cordon d'alimentation est débranché de la prise murale.

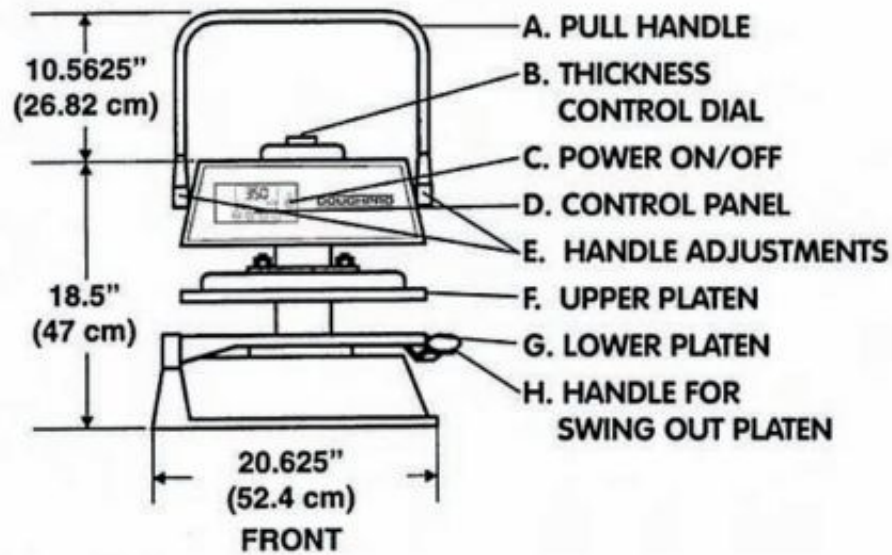

Familiarize yourself with the controls and operating mechanisms before using the Endurance X1.

(A) Pull-down pressing handle for raising and lowering the upper platen. This action forces the closing of the platens.

(B) Thickness control dial.

(C) On/Off button. The green light above the button will illuminate when powered on.

(D) Control Panel (See control board operations)

(E) Handle Adjustments (See tightening the pull-down handle)

(F) Upper Platen

(G) Lower Platen

(H) Handle for lower swing out platen.

Your dough press is equipped with a set of rubber mounting pads.

If you would prefer a set of legs which would raise your machine off the table 4 inches. Please contact sales at info@proluxe.com for a set. Shipping charges may apply.

OPERATION TEMPERATURE & TIMER CONTROL

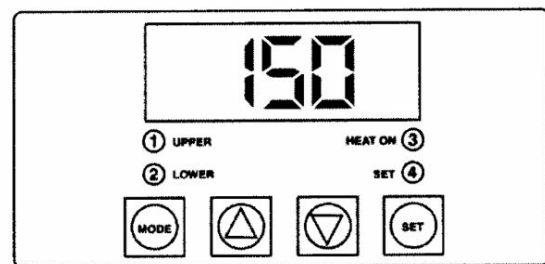

FIG. A

Solid State Controller

This controller has three (3) control features:

1. Temperature – May be set from 100°-425°F (38°-163°C)
2. Time – Time may be set from 1 second to 10 minutes.
3. Counter – Cycle counter counts the number of applications from 1 to 9999 (see additional Notes – Counter).
4. “2 Lower” (Fig. A) Refers to models using upper and lower heated surfaces.

Controller Operation

1. Viewing the Modes of Operation:

To view the set points of temperature, timer and counter, press MODE button to view the desired mode of operation.

2. Changing Temperature:

Press MODE button until temperature is displayed.

Press and hold SET button while pressing the UP (↑) and DOWN (↓) arrow buttons to desired temperature setting.

Fahrenheit/Celsius Conversion:

The temperature controller can be programmed to display either °F or °C. Press the MODE button until the temperature is displayed. Then push and hold the SET button for 10 seconds.

3. Changing Time:

Press MODE button until time is displayed. Press and hold SET button while pressing the UP (↑) and DOWN (↓) arrow buttons to desired timer setting.

4. Resetting the Counter:

Press MODE button until the counter is displayed.

To reset the counter (# of cycles), simultaneously push UP (↑) or DOWN (↓) arrow buttons (approx. 5 seconds).

PRESS OPERATION

Pressing Dough:

For best results, your dough should be proofed before pressing, but it will also press directly out of your refrigerator. Flour is not required to press a crust and **should not** be dusted on any part of the machine.

1. Check to see if you have the correct type of electrical current or serious damage could occur.
2. Press the power button, the green light above will illuminate when powered on.
3. Set your desired temperature on the control panel by using FIG. A and the instructions above. We recommend a temperature of 150°F. Testing with your own dough may desire a different setting.

Note: Heat is provided in the upper platen is only for purposes of enabling the dough to flow more rapidly in the pressing cycle. The heat IS NOT intended for baking.

4. Set the thickness control which is located on top of the machine. You can adjust this control to your needs and requirements.

Note: Diameter and thickness is determined through experimenting with your own dough and is a product of dough weight, temperature, pressing time, and thickness setting.

5. Swing open the lower platen and apply a quick spray of a good water based food release on the lower platen.

6. Place your pre-portioned ball of dough in the approximate center of the lower platen. Add another light spray to the top of the dough ball.

7. Close the platen and pull the handle down to begin pressing.

8. Hold the handle down and the timer will actuate and, when the time cycle is completed. Pull the handle back to starting position and remove your product.

9. Remove the finished product by rotating the lower platen until you have proper space to remove your dough.

10. Remove the crust, place on a pan or peel, add toppings and bake.

ADDITIONAL NOTES

Tightening the Pull-down Handle
The pull-down pressing handle requires adjustment periodically to prevent it from free falling. Whenever the handle becomes loose it can easily be tightened.

1. Using a 3/16" hex shaped Allen wrench, insert in key slot located on the right beneath the upper shroud.
2. Tighten until the press action of the handle becomes firm.

RECOMMENDED SEASONING & CLEANING PROCEDURES

Before use you must properly season your platens to prevent your dough from sticking.

Tools Required:

- Food release
- Soapy water solution
- Washcloth
- Paper towels

DO NOT use steel wool or harsh abrasives, it can cause costly damage.

1. Before cleaning make sure the unit is turned off.
2. Spray lower platen with approved food release/oil spray.
3. Wipe oil across lower platen with paper towel.
4. Wipe oil across upper platen.
5. Mix a warm dish soap and water solution.
6. Soak washcloth and wring to remove excess water.

7. Wipe lower and upper platen with damp cloth.

PREVENTATIVE MAINTENANCE

Proluxe machines are relatively maintenance free. For a long lifespan, the following preventative maintenance should be followed:

Daily Care:

1. Platens: Turn your machine off and allow to cool down before attempting to clean. These platens should only be cleaned with mild soap and warm water then wiped off with a clean, soft cloth or soft sponge.

2. Exterior surfaces: Wipe daily with mild soap and warm water will do the job quite nicely.

DO NOT use ice or cold water to cool the unit down. This can cause platens to warp.

Piston Maintenance:

In order to ensure pop and trouble free operation of the press piston, it is important that the machine be lubricated once every three months, under normal operation. High volume users may require more frequent lubrication.

Please follow these instructions:

1. Locate the grease port on the machine. Machines with pull down arms have a single grease port located below the upper head on the right side of the vertical post.
2. Place grease gun head against grease port and apply enough pressure to allow gun head to engage the grease port.
3. Squeeze handle of grease gun. This will force the grease into the piston.

The lubricant use must be USDA-H-I authorized for food machinery. This lubricant can be ordered through Proluxe, part # 110-002.

Service Problems:

Contact our factory at (800) 624-6717 (U.S. only) or approved service agency. When contacting the factory for information, parts or service instructions, please provide the serial number of the machine be provided. This number can be found on the serial plate located on the rear of the machine.

Endurance X1M Troubleshoot Guide - Model #: DP1100M

Problem	Cause	Action	Ref #
Power Button on Digital Controller face is depressed but doesn't turn on.	1. Power cord is not plugged in.	1. Plug the power cord into wall receptacle and power button.	68
	2. Circuit breaker is tripped off in the site's breaker box.	2. Reset circuit breaker that the grill is plugged into. Depress Power Button to turn on.	-----
	3. Transformer has taken an electrical surge and is damaged.	3. Replace Transformer after you check secondary side of transformer. If working properly, you should receive 12vdc.	91
	4. Check voltage on the secondary side of the Transformer. If you read 12VDC then you are receiving voltage to the controller.	4. Replace controller. Controller should be on once the power button is depressed.	85
	5. Possible blown fuse.	5. Replace fuse.	105
Digital Controller's LED's are scrambled or randomly erratic. If when turning on, the display will first go to segment check	1. Possibly a component on the Digital controller is damaged.	1. Replace digital controller.	-----
	2. Control needs to reset.	2. While unit is on unplug unit, wait for 1 min. Then plug machine on again and depress the power button.	85
Digital Controller on startup goes through LED segment check (8888) then to version # and then loops back to to the above reboot.	The relay driver on the digital control may be blown.	Replace digital controller.	85
Digital display shows PROB. No heat on Upper Platen.	Sensor lost it's continuity as shown on a muti-meter.	Disconnect prob that is open (no continuity as shown on a multi-meter. Must replace sensor (RTD). Do not cut and splice new sensor. Install new 2000 ohm RTD sensor to under side of heat platen and reconnect to the controller.	41
When depressing the	The tactile buttons under the overlay	Carefully (no too much at one	

tactile button on digital controller, nothing happens.	may be not close enough to activate. Same goes if the buttons are already pressed by overlay without depressing button.	time to avoid fracturing the traces on the controller) tighten the nuts on the back of the controller until button activate. Same goes in reverse if buttons are held down by the overlay.	
Digital display shows relay and particular zone is overheating. Beeper not functioning or intermittent beeper sound.	<ol style="list-style-type: none"> 1. The relay on the switched side is not opening to regulate temperature. 2. Beeper on digital control board failed. 	<ol style="list-style-type: none"> 1. Replace the relay. 2. Replace digital controller board 	<p>92</p> <p>85</p>
If setpoint is reached but slightly off in temperature.	Offset may need to be calibrated and adjusted.	Call (800) 624-6717 ext. 129 for instructions.	
Heater platen overheating	If the relay (depending on the year of the model) on the coil side are receiving 12vdc indicates the controller is functioning properly. On the switching side of the relay, is there 120 vac going to the heater in question. If there is no voltage on the to the switching side of the relay to the heaters, the relay is not working properly.	Replace relay If the controller's heat-on LED is not lit indicating the controller is working properly.	92
Dough not having same thickness across the press dough.	Adjust upper platen for level press	Underneath the housing there is 4 stacked hex bolts sitting over the upper platen attached to the arm. The top bolts are called locking bolts. The 4 larger hex bolts below are adjustment bolts. Break free the 4 locking bolts. With an open end wrench adjust the bolts (1/8 turn at a time). After testing, tighten the locking bolts making sure not to move the larger adjustment bolts	<p>11</p> <p>And</p> <p>12</p>

Explosion View

Model #: DP1100M

MASTER COPY
Date 06/01/18

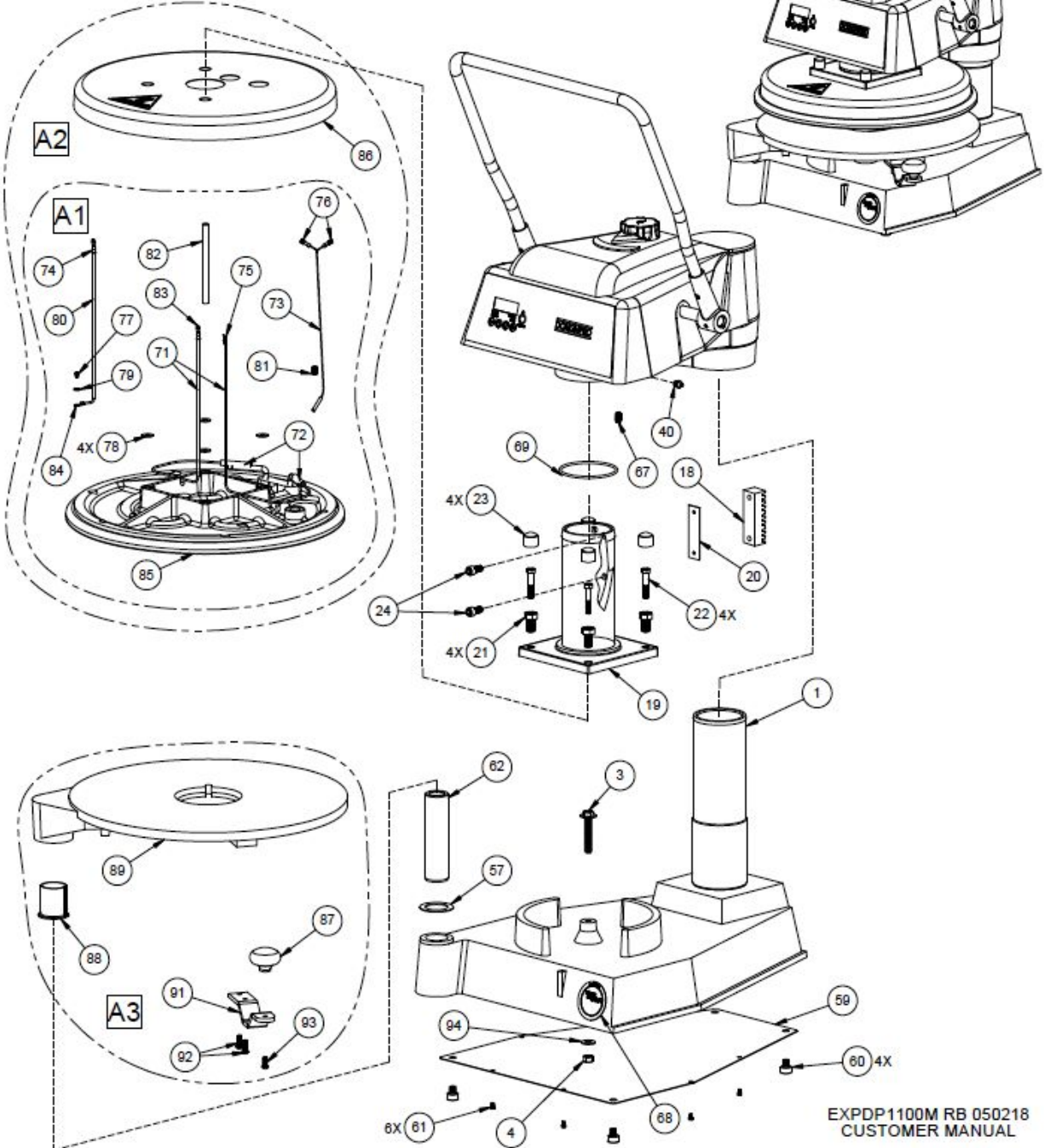

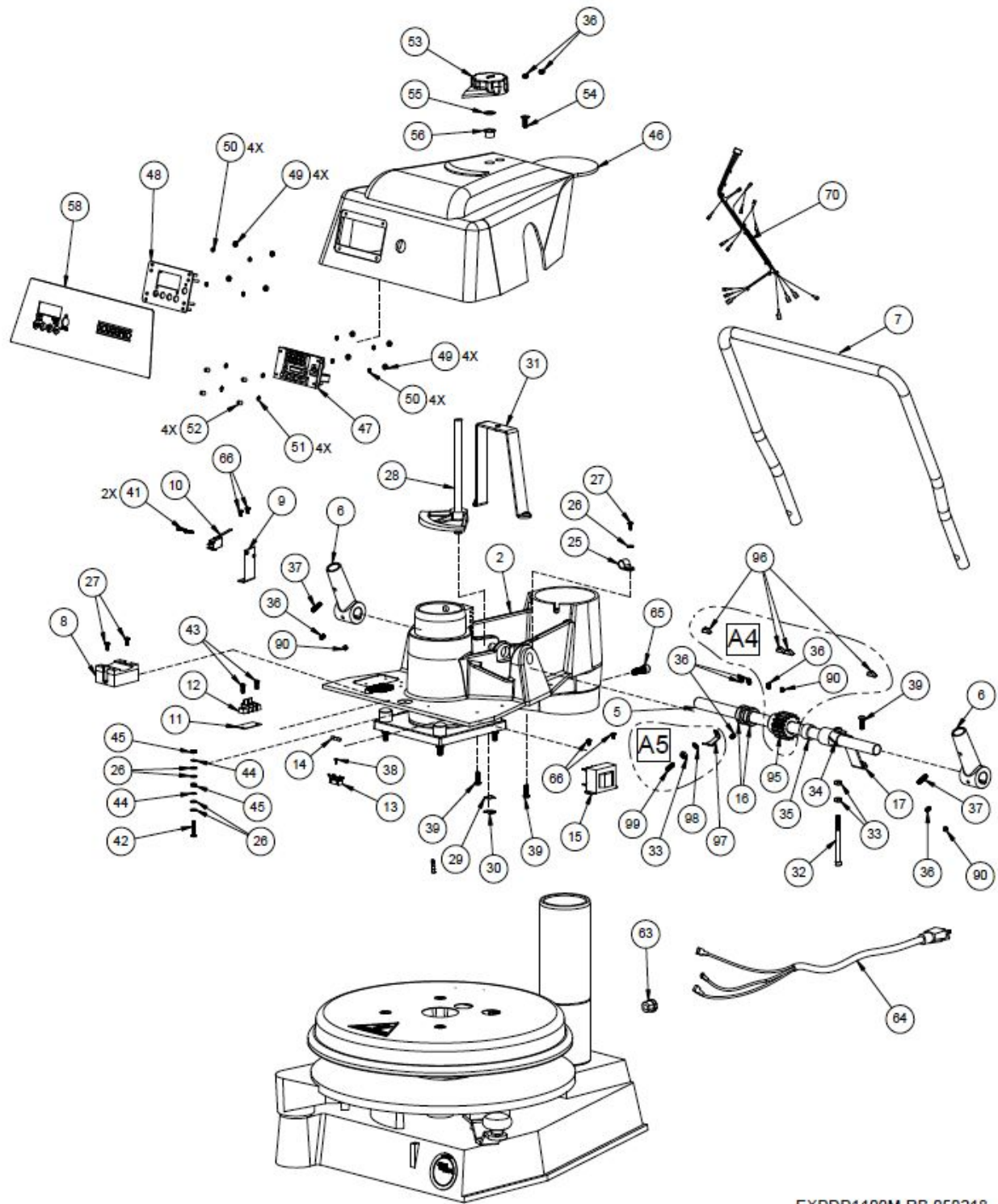

EXPDP1100M RB 050218
 CUSTOMER MANUAL

Endurance X1M Part List - Model #: DP1100M

ITEM NO.	DESCRIPTION	DP1100MA 120 ~ AC	DP1100MB 240 ~ AC	DP1100MGB 240 ~ AC	DP1100MCEB 240 ~ AC	DP1100MCEC 220 ~ AC	QTY.
1	BASE ASSEMBLY	110931101	110931101	110931101	110931101	110931101	1
2	ARM MACHINED	11010212101	11010212101	11010212101	11010212101	11010212101	1
3	LOWER PLATEN STOP, ASSEMBLY	110102130	110102130	110102130	110102130	110102130	1
4	NUT, HEX 3/8-16	NH3816	NH3816	NH3816	NH3816	NH3816	1
5	GEAR BAR	1109361	1109361	1109361	1109361	1109361	1
6	HANDLE SOCKET	11016650	11016650	11016650	11016650	11016650	2
7	HANDLE, PRESSURE	1109390	1109390	1109390	1109390	1109390	1
8	RELAY, SOLID STATE	MPR90217	MPR90217	MPR90217	MPR90217	MPR90217	1
9	MICROSWITCH BRACKET	1101021213	1101021213	1101021213	1101021213	1101021213	1
10	MICRO SWITCH	V15G31C25K	V15G31C25K	V15G31C25K	V15G31C25K	V15G31C25K	1
11	MARKER STRIP #2	MS6992	MS6992	MS6992	MS6992	MS6992	1
12	BLOCK, TERMINAL ASSY 2 STAGE	11096914	11096914	11096914	11096914	11096914	1
13	FUSE HOLDER 1 AMP	MPPF708	MPPF708	MPPF708	MPPF708	MPPF708	1
14	FUSE BUSS 1 AMP	MPPF701R	MPPF701R	MPPF701R	MPPF701R	MPPF701R	1
15	TRANSFORMER	11096975	11096975	11096975	11096975	11096975	1
16	COLLAR, GEAR BAR	11013183	11013183	11013183	11013183	11013183	2
17	ASSEMBLY, TENSION STRAP	11041663	11041663	11041663	11041663	11041663	1
18	RACK, GEAR	1109380	1109380	1109380	1109380	1109380	1
19	ASSEMBLY, PISTON	11018974	11018974	11018974	11018974	11018974	1
20	SHIM, GEAR RACK	110144120	110144120	110144120	110144120	110144120	1
21	BOLT, LEVEL ADJUSTMENT	1109367	1109367	1109367	1109367	1109367	4
22	BOLT, HEX 5/16-18 X 1 3/4" GR5	BH51618134G 5	BH51618134G 5	BH51618134G 5	BH51618134G 5	BH51618134G 5	4
23	CAP, VINYL (ADJUSTMENT SCREWS)	SC0687	SC0687	SC0687	SC0687	SC0687	4
24	SCREW, SOCKET HEAD 3/8-16 X 3/4	SSH381634	SSH381634	SSH381634	SSH381634	SSH381634	2
25	CLAMP, CABLE 3/8	CC38	CC38	CC38	CC38	CC38	1
26	WASHER, SAE #8	WSAE8	WSAE8	WSAE8	WSAE8	WSAE8	5
27	SCREW, PHILLIPS PAN HEAD 8-32 X 3/8	SP83238	SP83238	SP83238	SP83238	SP83238	3
28	CAM RAMP ASSEMBLY	1109310	1109310	1109310	1109310	1109310	1
29	WASHER, WAVE .505 I.DX.750 O.D, X .045	5806282	5806282	5806282	5806282	5806282	1
30	CLIP "E" RETAINING 1/2	MPSC240	MPSC240	MPSC240	MPSC240	MPSC240	1

31	BRACKET, HOUSING ASSEMBLY	110144130	110144130	110144130	110144130	110144130	1
32	SCREW, SOCKET HEAD 1/4-20 X 3 1/4	SSH1420314	SSH1420314	SSH1420314	SSH1420314	SSH1420314	1
33	NUT, HEX 1/4-20	NH1420	NH1420	NH1420	NH1420	NH1420	3
34	BUSHING, TENSION STRAP	11018966	11018966	11018966	11018966	11018966	1
35	BUSHING, SPACER	11024369	11024369	11024369	11024369	11024369	1
36	SCREW, SET 1/4-20 X 3/8	SST142038	SST142038	SST142038	SST142038	SST142038	6
ITEM NO.	DESCRIPTION	DP1100MA 120 ~ AC	DP1100MB 240 ~ AC	DP1100MGB 240 ~ AC	DP1100MCEB 240 ~ AC	DP1100MCEC 220 ~ AC	QTY.
37	SCREW, SET SOCKET HEAD 1/4-20 X 7/8	SST142078	SST142078	SST142078	SST142078	SST142078	2
38	SCREW, PHILLIPS PAN 2-56 X 1/4	SP25614	SP25614	SP25614	SP25614	SP25614	1
39	SCREW, BUTTON HEAD 1/4-20X3/4	SB142034	SB142034	SB142034	SB142034	SB142034	3
40	FITTING, ZERK 1/4-28	B792	B792	B792	B792	B792	1
41	SCREW, ROUND HEAD 4-40 X 5/8 SLOTTED	SR44058	SR44058	SR44058	SR44058	SR44058	2
42	SCREW, PAN HEAD 8-32 X 1	SP8321	SP8321	SP8321	SP8321	SP8321	1
43	SCREW, PAN HEAD PHILLIPS 8-32 X 1/2	SP83212	SP83212	SP83212	SP83212	SP83212	2
44	WASHER, INTERNAL TOOTH LOCK #8	WLIT8	WLIT8	WLIT8	WLIT8	WLIT8	2
45	NUT, HEX 8-32	NH832	NH832	NH832	NH832	NH832	2
46	HOUSING MACHINED	11017815422 01	11017815422 01	11017815422 01	11017815422 01	11017815422 01	1
47	DIGITAL CONTROL	11096905211	11096905211	11096905211	11096905211	11096905211	1
48	ASSEMBLY, CONTROL FACIA	11086027	11086027	11086027	11086027	11086027	1
49	NUT, HEX 6-32	NH632	NH632	NH632	NH632	NH632	8
50	WASHER, INTERNAL TOOTH LOCK #6	WLIT6	WLIT6	WLIT6	WLIT6	WLIT6	8
51	WASHER, STEEL	311150019	311150019	311150019	311150019	311150019	4
52	NYLON SPACER, 1/4 X .141 X 9/32 LONG	110969111	110969111	110969111	110969111	110969111	4
53	KNOB, THICK/THIN MACHINED	1109309	1109309	1109309	1109309	1109309	1
54	SCREW, SOCKET FLAT HEAD 1/4-20 X 3/4	SF142034	SF142034	SF142034	SF142034	SF142034	1
55	SHIM WASHER	WS12031	WS12031	WS12031	WS12031	WS12031	1
56	BUSHING, FLANGE	212NN014200 00	212NN014200 00	212NN014200 00	212NN014200 00	212NN014200 00	1
57	SHIM, LOWER PLATEN	11037932205 5	11037932205 5	11037932205 5	11037932205 5	11037932205 5	1
58	OVERLAY, DIGITAL CONTROL PANEL	ODP1100	ODP1100	ODP1100	ODP1100	ODP1100	1

59	COVER PLATE, BASE	11010954	11010954	11010954	11010954	11010954	1
60	FEET, RUBBER	RF209	RF209	RF209	RF209	RF209	4
61	BOLT, HEX 8-32 X 1/4	BH83214	BH83214	BH83214	BH83214	BH83214	6
62	POST, LOWER PLATEN	11015960	11015960	11015960	11015960	11015960	1
63	CABLE STRAIN RELIEF	MPSS168	MPSS168	MPSS168	MPSS168	MPSS168	1
64	POWER CORD	110969174	110969175	DP149203	MPPW202	MPPW202	1
65	SCREW, SOCKET HEAD 3/8-16 X 1	SSH38161	SSH38161	SSH38161	SSH38161	SSH38161	1
ITEM NO.	DESCRIPTION	DP1100MA 120 ~ AC	DP1100MB 240 ~ AC	DP1100MGB 240 ~ AC	DP1100MCEB 240 ~ AC	DP1100MCEC 220 ~ AC	QTY.
66	SCREW, PHILLIPS PAN HEAD 8-32 X 1/4	SP83214	SP83214	SP83214	SP83214	SP83214	4
67	DETENT, PLUNGER SPRING 3/8-16	MPSP134	MPSP134	MPSP134	MPSP134	MPSP134	1
68	DECAL USA STICKER	DPROUSA	DPROUSA	DPROUSA	DPROUSA	DPROUSA	1
69	ORING, #2-28 N-70, PISTON	238N70	238N70	238N70	238N70	238N70	1
70	WIRE HARNESS	110560051	110560051	110560051	110560051	110560051	1
71	WIRE, TGGT, 14GA. (HEATER)	110069	110069	110069	110069	110069	7 FT.
72	TFE SHRINK TUBING	110131	110131	110131	110131	110131	.33 FT.
73	SENSOR ASSEMBLY	110949110	110949110	110949110	110949110	110949110	1
74	TERMINAL, RING #8	1604	1604	1604	1604	1604	1
75	14-16 GA #10 FORK TERMINAL INSUL.	1626	1626	1626	1626	1626	1
76	TERMINAL Q.D. 3/16 X 18/22GA.	2280	2280	2280	2280	2280	2
77	SCREW, PAN HEAD 6-32 X 1/4	SP63214	SP63214	SP63214	SP63214	SP63214	1
78	WASHER, SAE 5/16	WSAE516	WSAE516	WSAE516	WSAE516	WSAE516	4
79	WASHER, SAE #6	WSAE6	WSAE6	WSAE6	WSAE6	WSAE6	1
80	WIRE, TFE 14GA. GREEN	WTFE14G	WTFE14G	WTFE14G	WTFE14G	WTFE14G	3.08 FT.
81	SCREW, SET 3/8-16 X 1/2	SST381612	SST381612	SST381612	SST381612	SST381612	1
82	SLEEVING, PVC WIRE	OPVC1050	OPVC1050	OPVC1050	OPVC1050	OPVC1050	1.33 FT.
83	TERMINAL, FEMALE MOLEX	MPSQ100	MPSQ100	MPSQ100	MPSQ100	MPSQ100	1
84	TERMINAL, RING #6	1601HT	1601HT	1601HT	1601HT	1601HT	1
86	SHROUD, UPPER PLATEN	1109336	1109336	1109336	1109336	1109336	1
87	KNOB, SWING AWAY	110017	110017	110017	110017	110017	1
88	FLANGED BUSHING MACHINED	110102167	110102167	110102167	110102167	110102167	1
90	SCREW, SET 1/4-20 X 1/4"	SST142014	SST142014	SST142014	SST142014	SST142014	3
91	HANDLE LOWER PLATEN	1106301	1106301	1106301	1106301	1106301	1

92	SCREW, BUTTON HEAD 1/4-20 X 3/4	SB142034	SB142034	SB142034	SB142034	SB142034	2
93	SCREW, BUTTON HEAD 1/4-20 X 5/8	SB142058	SB142058	SB142058	SB142058	SB142058	1
94	WASHER, SAE 3/8	WSAE38	WSAE38	WSAE38	WSAE38	WSAE38	1
95	PINION GEAR ASSEMBLY	1109360	1109360	1109360	1109360	1109360	1
ITEM NO.	DESCRIPTION	DP1100MA 120 ~ AC	DP1100MB 240 ~ AC	DP1100MGB 240 ~ AC	DP1100MCEB 240 ~ AC	DP1100MCEC 220 ~ AC	QTY.
96	KEYWAY, #9 3/16 X 3/4	KW931634	KW931634	KW931634	KW931634	KW931634	4
97	BRACKET, MICRO SWITCH	110200019	110200019	110200019	110200019	110200019	1
98	WASHER, SPLIT LOCK, 1/4	WL14	WL14	WL14	WL14	WL14	1
99	SCREW, SET 1/4-20 X 3/4 CONE POINT	SST142034CP	SST142034CP	SST142034CP	SST142034CP	SST142034CP	1
100	MANUAL DP1100M	MDP1100M	MDP1100M	MDP1100M	MDP1100M	MDP1100M	1
A1	UPPER PLATEN WIRE ONLY	110074120K	110074240K	110074240K	110074240K	110074220K	1
A2	UPPER PLATEN COMPLETE ASSEMBLY	110074120AK	110074240AK	110074240AK	110074240AK	110074220AK	1
A3	LOWER PLATEN ASSEMBLY	11076632K	11076632K	11076632K	11076632K	11076632K	1
A4	PINION GEAR ASSEMBLY	1109360K	1109360K	1109360K	1109360K	1109360K	1
A5	KIT, MICRO SWITCH BRACKET ASSEMBLY	110200019K	110200019K	110200019K	110200019K	110200019K	1

VAC: 120/208/240
 AMPS: 12.5/11.1/8.25
 WATTS: 1500W/2300W/1500W

PROLUXE™
 DP-100 WIRE DIAGRAM

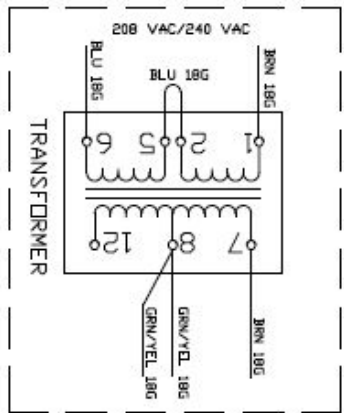
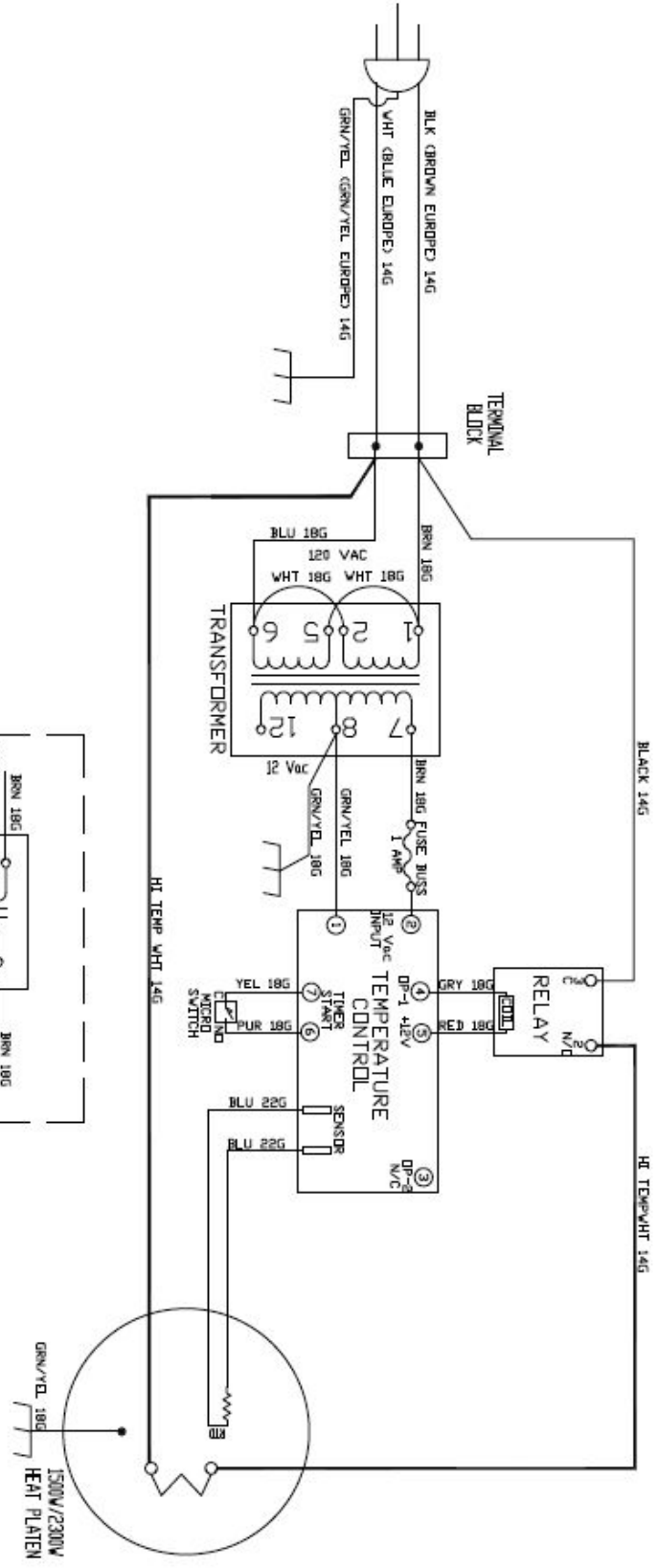

MASTER COPY
 Date 06/05/14

WDDP1100 RA 16611,30000 060514

Warranty & Return Policy

Proluxe warrants all products manufactured by it against defects in workmanship or materials from the date of purchase for a period of 1 year on parts and labor. This warranty applies to only equipment purchased and used in the United States.

Warranty period shall begin when equipment ships. Warranty travel will only be covered for 60 miles.

ALL WARRANTY SERVICE CALLS MUST BE APPROVED BY PROLUXE. IF THIS PROCEDURE IS NOT FOLLOWED, WARRANTY SERVICE WILL NOT BE COVERED. WARRANTY SERVICE WILL BE PAID ON STRAIGHT TIME, OVERTIME WILL NOT BE COVERED.

EXCLUSIONS

Wood & Gas Fired Ovens

Warranty applies to the main body of the oven being steel / refractory and insulation shall be free from defects in materials and workmanship for a period of four years from the date of purchase. The gas equipment shall be free from defects in materials and workmanship for a period of one (1) year from the date of purchase. Lifetime warranty against cracks on the oven floor.

Special Order Equipment and Accessories

Cannot be canceled and are not returnable unless defective within the terms of this warranty.

In no event shall Proluxe be liable for consequential damages arising out of the failure of any of its products if operated improperly or caused by normal wear or damaged by operator abuse.

Limited Lifetime Warranty on Heating Elements

If replacement is needed, Proluxe will send the new part at no charge but labor will not be covered unless the unit is still under the 1 year manufacturer warranty.

RETURNED MERCHANDISE POLICY

Should it become necessary to return any of the company's products, the following instructions must be adhered to: First, contact our customer service department for approval and a return authorization number. Please have the serial number of your item available at that time. All merchandise must be shipped freight prepaid by customer or service agency. Subject to the inspection of the product by the company, a restocking charge of 20% of the Net purchased price paid to Proluxe will be assessed. Merchandise may not be returned for credit without prior written approval of Proluxe.

Collect shipments will not be accepted. No returns after 60 days of original shipment

date on machines. Purchased parts may not be returned after 30 days. If upon inspection by Proluxe or its authorized agent it is determined the equipment has not been used in an appropriate manner, has been modified, or has not been properly maintained, or has been subject to misuse, misapplication, neglect, abuse, accident, unauthorized modification, damage during transit, delivery, fire, flood, act or war, riot or act of God, then this warranty shall be deemed null and void.

TERMS & CONDITIONS

1. Price List prices are suggested retail prices and are shown in U.S. Dollars.

2. Terms of Payment: 1% 10 days, NET 30 days.

3. New Accounts: Satisfactory credit information must be provided before open account status can be extended.

Unless agreed otherwise, all shipments will be made C.O.D., Cash in advance.

4. Pricing: Prices, specifications, model numbers, capacities and accessories are subject to change without notice.

5. Freight/Routing: Method of shipment will be determined by Proluxe unless otherwise advised by purchaser.

6. Damaged Claims: All merchandise shipped at purchaser's risk. Inspection must be made by purchaser at time goods are received. If goods are damaged, the PURCHASER shall request that the agent of the transportation company make a written notation on the proper shipping documents immediately and then file a claim for damages.

Note: Goods damaged in shipping are non-returnable.

7. Returns: Machines may not be returned after 60 days. Purchased parts may not be returned after 30 days. A restocking fee of 20% will be assessed on non-warranty returns.

8. Taxes: Prices indicated herein DO NOT include State, Federal, Local or foreign taxes or duties, nor do they include fees, permits, insurance or other levies, all of which are the responsibility of the purchaser.

9. All orders are subject to acceptance by Proluxe.

10. Possession of this price list shall not be considered an offer to sell.